

COUNTERS & METERS

CONTENTS

MAINS ANALYSERS	Page 336
ANALOGUE MEASURING INSTRUMENTS FOR CP	Page 340
ELECTRONIC 1-PHASE/3-PHASE METERS	Page 345
MODULAR LOW-CURRENT TRANSFORMERS	Page 346
CURRENT TRANSFORMERS	Page 347
HOUR METER	Page 351

MAINS ANALYSERS

LOW VOLTAGE NETWORK MONITOR NA96



MGF39000

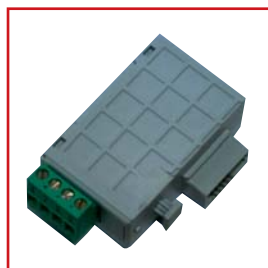

MGF3900A

TECHNICAL DATA

- Three-phase line 80...500V (phase - phase)
- Connection with external dedicated CT
- Programmable external CT-VT ratio

DISPLAY

- Type of display: LCD backlit, automatic backlit reduction off after 20 s that keyboard is not used
- N° of display points: 10.000, 4 digits (high digit 12 mm)
- Energy count: 8 digit counter (high digit 8 mm)
- Engineering units: automatic display according to the set VT and CT ratios
- Resolution: automatic, with the highest possible number of decimals
- Decimal point: automatic, with the highest possible resolution
- Reading update: 1,1 seconds
- Accuracy (of the reading):
 - Voltage: $\pm 0,5\%$ (80...500V phase - phase)
 - Current: $\pm 0,5\%$ (10...120% I_n)
 - Powers: $\pm 1\%$ (10...120% $P_n/Q_n/S_n \cos \varphi$ 0,5 ind...0,5 cap.)
 - Frequency: $\pm 0,2$ Hz
- Energy count (reference voltage 400 V):
 - Active energy: class 1 (EN62053-21)
 - Reactive energy: class 2 (EN62053-23)

DISPLAY PAGES

Display is divided into four menus which can be reached with the relevant function keys:

voltage / current / power three-phase / power factor

The total active or reactive energy (alternatively) is always displayed on all the display pages.

PROGRAMMING

- Parameters programming: front keyboard, 4 keys
- Programming access: protected by password
- Data and configuration parameters retention: non volatile memory (no battery)

PROGRAMMABLE PARAMETER

INPUT:

- Connection: single-phase and three-phase network, 3 and 4 wire
- Current rating: 1 – 5 A
- External VT ratio: 1...10 (max. VT primary 1200 V)
- External CT ratio: 1...9999 (max. CT primary 50 kA/5A – 10 kA/1A)

CURRENT DEMAND – POWER DEMAND:

- Average period: 5/8/10/15/20/30/60 min.

DISPLAY:

- Contrast: 4 selectable value
- Backlit: 0 – 30 – 70 – 100%
- Customized page: quantity which can be displayed when switches on

MAINS ANALYSERS

LOW VOLTAGE NETWORK MONITOR NA96 – continued

INPUT

- Single-phase network, three-phase network 3- and 4-wire
- Three-phase voltage: 80...500V (phase-phase)
- Single-phase voltage: 50...290V
- Connection with external dedicated current transformers
- Current rating I_n : 5A – 1A
- Max. current I_{max} : 1,2 I_n
- Instantaneous overload: 20 I_n /0,5 seconds
- Frequency rating f_n : 50Hz
- Tolerance: 47...63Hz
- Type of measurement: true RMS value
- Harmonic content: up to the 16th harmonic
- Voltage rated burden: $\leq 0,5VA$ (each phase)
- Current rated burden: $\leq 0,5VA$ (each phase)

AUXILIARY SUPPLY

- Rated value U_{aux} ac: 80...265V
- Rated frequency: 50Hz
- Working frequency: 47...63Hz
- Rated burden: $\leq 4VA$ (with modules)
- Rated value U_{aux} dc: 110...300VDC
- Rated burden: $\leq 3,5W$ (with modules)
- Protected against incorrect polarity

INSULATION (EN 61010-1)

- Installation category: III
- Pollution degree: 2
- Insulation voltage rating: 300V (phase neutral)
- Impulse voltage test: 6kV 1,2/50 μ s 0,5J
- Considered circuits: measure, aux. supply
- A.C. voltage test: 4kV r.m.s. value 50Hz/1min
- Considered circuits: all circuits and earth

TESTS FOR ELETROMAMAGNETIC COMPATIBILITY

- Emission and Immunity tests according to EN 62052-11

ENVIRONMENTAL CONDITIONS

- Reference temperature: 23°C \pm 2°C
- Specified operating range: -5...55°C
- Limit range for storage and transport: -25...70°C
- Variation to the class index: $\leq 0,1\%$ /°C
- Suitable for tropical climates
- Max. power dissipation ¹⁾: $\leq 5W$
¹⁾ For switchboard thermal calculation

HOUSING

- Housing: flush mounting (panel cutout 92 x 92mm)
- Front frame: 96 x 96 mm
- Depth: 61 mm
- Max. depth: 81 mm (with optional modules)
- Connections: screw terminals (input current) to plug out (input voltage)
- Volmetric terminals range: rigid cable max. 4,5 mm², flexible cable max. 2,4 mm²
- Ammetric terminals range: rigid cable max. 6 mm², flexible cable max. 4 mm²
- Housing material: self-extinguishing polycarbonate
- Protection degree (EN60529): IP54 front frame, IP20 terminals
- Weight: 285 grams

DESCRIPTION	ORDER NO.
Netanalyser	MGF39000
Modul for alarm contacts	MGF3900A
Modul for impulse contacts	MGF3900I
Modul for analog contacts	MGF3900M
Modul with RS485 interface	MGF3900R
Modul with profibus interface	MGF3900P

MAINS ANALYSERS

NETANALYSER MF7



MGF37000

TECHNICAL DATA

- Three-phase network 340...450V (phase - phase)
- Single-phase 195...260V (phase - neutral)
- Connection with dedicated CT
- Programmable primary CT 5...8000A (41 ranges)
- True RMS value measurement

DISPLAY PAGES

page	three-phase 4-wire S1000/227	single-phase S1000/228
1	phase current	current + frequency + voltage
2	phase voltage	current demand + current max. demand
3	phase-to-neutral voltage	working hours and minutes
4	neutral current + frequency	
5	current demand	
6	current max. demand	
7	working hours and minutes	

DISPLAY

- Phase and linked voltage
- Phase and neutral current
- Frequency
- Current demand
- Max. current demand
- Working hours and minutes (run hour meter)
- N° of display points: 10.000 (4 digits)
- Engineering units: automatic display
- Resolution: automatic, with the highest possible number of decimals
- Run hour meter: hours and minutes
- Reading update: 1,2 seconds
- Accuracy (of the reading):
 - Voltage: $\pm 0,5\%$ (80...600V phase - phase)
 - Current: $\pm 0,5\%$ (10...120% In)
 - Neutral current: $\pm 2\%$
 - Frequency: $\pm 0,2$ Hz

CURRENT DEMAND

- Display: Current demand and max. current demand
- Average period: 5/8/10/15/20/30/60 minutes selectable
- Calculation: average on a selected period
- Peak max. demand reset: by hand, by keyboard

PROGRAMMING

- Parameters programming: front keyboard, 2 keys
- Programming access: key combination
- Data and configuration parameters retention: non volatile memory (no battery)

PROGRAMMABLE PARAMETER

- Connection: single-phase - three-phase 4 wire
- External CT primay: 41 ranges (see table)

SELECTABLE PRIMARY CURRENT (A)

5					10			15		20	25	30		40
50	60	70	75	80	100	120	125	150	160	200	250	300		400
500	600	700	750	800	1000	1200	1250	1500	1600	2000	2500	3000	3200	4000
5000	6000	7000	7600	8000										

- Current max. demand: delay time, reset
- Working hours: reset

MAINS ANALYSERS

NET ANALYSER MF7 – continued

INPUT

- Single-phase and three-phase 4-wire network
- Three-phase voltage: 340...450V (phase-phase)
- Single-phase voltage: 195...260V
- Current rating I_n : 5A or 1A
- Continuous overload: $1,2I_n$
- Instantaneous overload: $20I_n/0,5$ seconds
- Connection with external dedicated current transformer
- Inputs have a common point
- Frequency rating f_n : 50Hz
- Tolerance: 47...63Hz
- Type of measurement: true RMS
- Harmonic content: up to the 16th harmonic
- Voltage rated burden: $\leq 1VA$ (each phase)
- Current rated burden: $\leq 0,5VA$ (each phase)

AUXILIARY SUPPLY

- Taken from measurement (selfsupplied)

INSULATION (EN 60439-1)

- Installation category: III
- Pollution degree: 2
- Insulation voltage rating: 660V
- A.C. voltage test: 4kV r.m.s. value 50Hz/1min
- Considered circuits: all circuits and earth

TESTS FOR ELETROMAMAGNETIC COMPATIBILITY

- Emission tests according to EN 61000-6-3
- Immunity tests according to EN 61000-6-2

ENVIRONMENTAL CONDITIONS

- Reference temperature: $23^{\circ}C \pm 2^{\circ}C$
- Specified operating range: $-5...55^{\circ}C$
- Limit range for storage and transport: $-25...70^{\circ}C$
- Variation to the class index: $\leq 0,1\% / ^{\circ}C$
- Suitable for tropical climates
- Max. power dissipation ¹⁾: $\leq 6,8W$
¹⁾ For switchboard thermal calculation

HOUSING

- Housing: flush mounting (panel cutout 68x68mm)
- Front frame: 72 x 72 mm
- Depth: 75 mm
- Ammetric terminals range: rigid cable min. $0,05 \text{ mm}^2$ / max. 4 mm^2 flexible cable min. $0,05 \text{ mm}^2$ / max. $2,5 \text{ mm}^2$
- Voltmetric terminals range: rigid cable min. $0,05 \text{ mm}^2$ / max. 4 mm^2 flexible cable min. $0,05 \text{ mm}^2$ / max. $2,5 \text{ mm}^2$
- Housing material: self-extinguishing makrolon
- Protection degree (EN60529): IP54 front frame, IP20 terminals
- Weight: 250 grams

WIRING DIAGRAMS

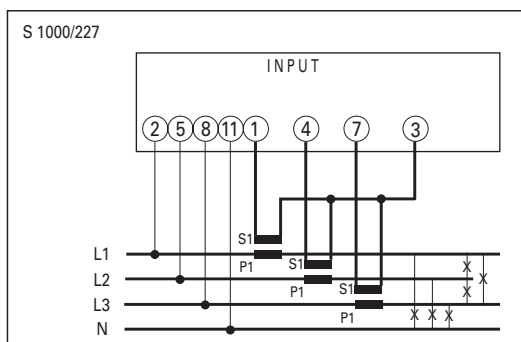

Three-phase network 4-wire

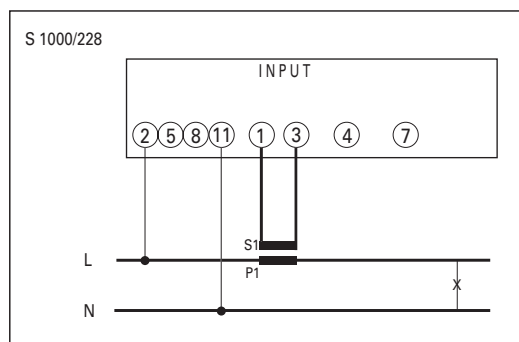

Single-phase network

DIMENSIONS

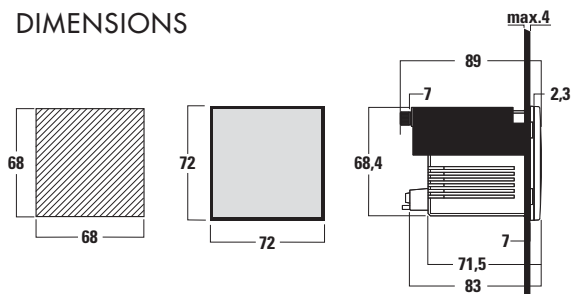

DESCRIPTION

Netanalyser MF7

ORDER NO.

MGF37000

ANALOGUE MEASURING INSTRUMENTS FOR CP

ANALOGUE MEASURING INSTRUMENTS FOR CONTROL PANEL INSERT

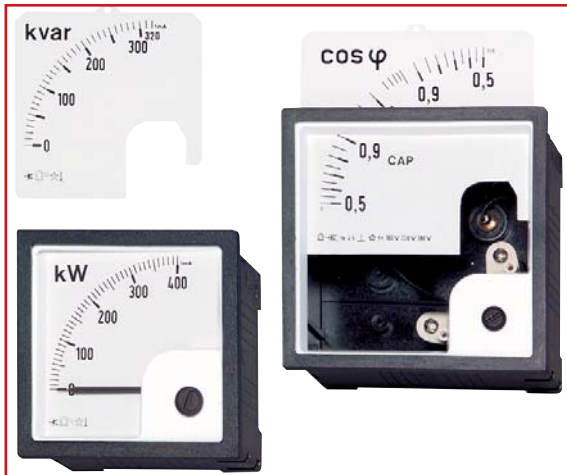

ANALOGUE MEASURING INSTRUMENTS FOR CONTROL PANEL INSERT

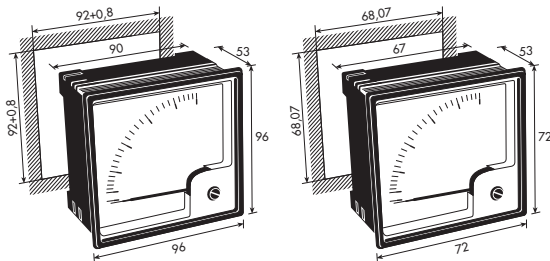

SCHRACK-INFO

In accordance with DIN 43700/43718, IEC 51,
Housing made from selfextinguishing plastic
Class V0 accord. to UL-94

- Class $\pm 1,5$
- Rated voltage max. 600 V
- 90° scale (240° scale on request)
- Degree of protection IP 52 (from front), IP 54 optional
- Test voltage 2 kV, 50 Hz, 1 Min.
- Vibration-proof

ACCESSORIES

- Changeable scales
- Terminal cover

Symbols and explanations for the measuring devices

Symbols for the functioning of the devices		Symbols for device connection	
Description	Symbol	Description	Symbol
Moving coil measuring device		Measuring device for DC	
Moving iron measuring device		Measuring device for AC single phased	
Electrodynamic measuring device		Measuring device for DC and AC single phased	
Induction measuring device		3-phase current general	
Bi-metal measuring device		3-phase current uneven load (general)	
Vibration measuring device		Measuring device for 3-conductor system	
Measuring device with electronics		Measuring device for 4-conductor system	
Electronics with auxiliary measuring device		Two measuring devices for 3-conductors, uneven load	
Shunt		Two measuring devices for 4-conductors, even load	
General accesories		Three measuring devices for 4-conductors, uneven load	

In case of (1) being marked with the symbol for measuring device, electronics is installed. In case of (1) being combined with (2), it means external parts

Symbols for accuracy classes		Symbols for service position		Safety symbols	
Description	Symbol	Description	Symbol	Description	Symbol
Class symbol (e.g. 1.5) with error expressed in % of the reference value, except when the reference value corresponds with the scale length or the real value. Indication error in % of the scale end value	1,5	Devices for perpendicular nominal position		Control voltage 500V	
Indication error in % of the rated value		Devices for horizontal nominal position		Control voltage over 500V e.g. 2kV	
Class symbol for a device without linear scale Used in case of reference value corresponding to scale length and indication error expressed in % of the real value, e.g. cl.1, relative error margin 5% (Par. 2.3.11.36)		Devices for inclined nominal position (e.g. 60° inclination)		No control voltage	
				High voltage on accessories or on device	

ANALOGUE MEASURING INSTRUMENTS FOR CP

AMMETER AC 72x72, 96x96 mm



MG1BA000

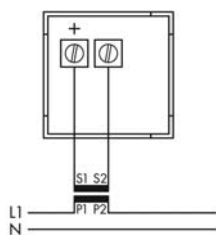

Connection to current transformer

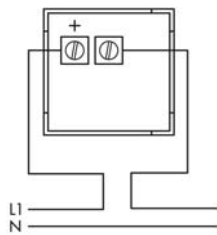

Direct connection

SCHRACK-INFO

- Moving iron type, overcurrent range 2x In
- RI series 0,25 to 60 A AC direct, 10 A to 10 kA via current transformer connection
- Frequency 45-65 Hz

TIPS & TRICKS

The instruments with a transformer connection are supplied with a scale. This is because the scale must be chosen in accordance with the transformer. Order the changeable scale separately.

MEASUREMENT RANGE	DIM. (WxHxD) mm	ORDER NO.
AMMETER		
5 A	72x72x53	MGF57005
10 A	72x72x53	MGF57010
25 A	72x72x53	MGF57025
../5 A, transformer connection, w/o scale	72x72x53	MGF57000
5 A	96x96x53	MGF59005
10 A	96x96x53	MGF59010
15 A	96x96x53	MGF59015
25 A	96x96x53	MGF59025
50 A	96x96x53	MGF59050
../5 A, transformer connection, w/o scale	96x96x53	MGF59000
SCALE PLATE 72x72		
Scale plate, 50/100 A	72x72	MGS57050
Scale plate, 60/120 A	72x72	MGS57060
Scale plate, 80/160 A	72x72	MGS57080
Scale plate, 100/200 A	72x72	MGS57100
Scale plate, 150/300 A	72x72	MGS57150
Scale plate, 200/400 A	72x72	MGS57200
Scale plate, 250/500 A	72x72	MGS57250
Scale plate, 300/600 A	72x72	MGS57300
Scale plate, 400/800 A	72x72	MGS57400
Scale plate, 500/1000 A	72x72	MGS57500
Scale plate, 600/1200 A	72x72	MGS57600
Scale plate, 800/1600 A	72x72	MGS57800
Scale plate, 1000/2000 A	72x72	MGS571K0
Scale plate, 1500/3000 A	72x72	MGS571K5

ANALOGUE MEASURING INSTRUMENTS FOR CP

AMMETER AC 72x72, 96x96 mm – continued

MEASUREMENT RANGE	DIM. (WxHxD) mm	ORDER NO.
SCALE PLATE 96x96		
Scale plate, 60/120 A	96x96	MGS59060
Scale plate, 80/160 A	96x96	MGS59080
Scale plate, 100/200 A	96x96	MGS59100
Scale plate, 150/300 A	96x96	MGS59150
Scale plate, 200/400 A	96x96	MGS59200
Scale plate, 250/500 A	96x96	MGS59250
Scale plate, 300/600 A	96x96	MGS59300
Scale plate, 400/800 A	96x96	MGS59400
Scale plate, 500/1000 A	96x96	MGS59500
Scale plate, 600/1200 A	96x96	MGS59600
Scale plate, 800/1600 A	96x96	MGS59800
Scale plate, 1000/2000 A	96x96	MGS591K0
Scale plate, 1500/3000 A	96x96	MGS591K5
Scale plate, 2000/4000 A	96x96	MGS592K0
Scale plate, 2500/5000 A	96x96	MGS592K5
Scale plate, 3000/6000 A	96x96	MGS593K0

VOLTMETER AC 72x72, 96x96 mm

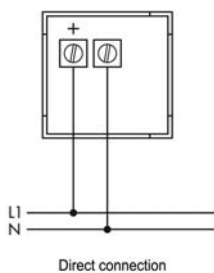

SCHRACK-INFO

- RI series 6 to 600 V AC direct

MEASUREMENT RANGE	DIM. (WxHxD) mm	ORDER NO.
300 V	72x72x53	MGF67300
500 V	72x72x53	MGF67500
300 V	96x96x53	MGF69300
500 V	96x96x53	MGF69500

VOLTMETER AC WITH INTEGRATED SWITCH FOR PHASES 72x72, 96x96 mm



MGF77500

SCHRACK-INFO

- 500 V AC direct
- With integrated switch
L1-L2, L2-L3, L3-L1, L1-N, L2-N, L3-N

DESCRIPTION	DIM. (WxHxD) mm	ORDER NO.
500 V	72x72x53	MGF77500
500 V	96x96x53	MGF79500

ANALOGUE MEASURING INSTRUMENTS FOR CP

■ FREQUENCY METER AC 72x72, 96x96 mm



MG3B705F

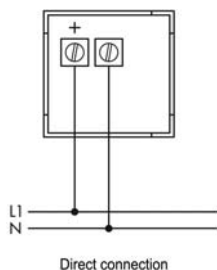

■ SCHRACK-INFO

- Intrinsic consumption 1,5-3 VA
- 110-230-400 V
- Class 0,5
- Double-reed type available upon request

DESCRIPTION	DIM. (WxHxD) mm	ORDER NO.
Frequency meter, 45 to 65 Hz, 230 V	72x72x53	MGF87050
Frequency meter, 45 to 65 Hz, 230 V	96x96x53	MGF89050

■ AMMETER DC 72x72 mm



MG1BD000

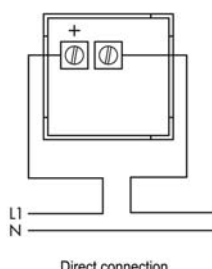
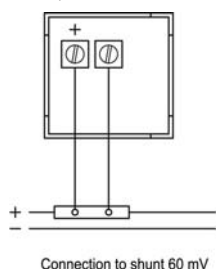

■ SCHRACK-INFO

- RC series moving coil mechanism
- 50 to 900 μ A, 1 to 900 mA, 1 to 60 A direct
- 10 A to 10 kA via shunt
- Other changeable scales/measuring ranges for higher currents are available upon request.
- Order the changeable scale separately!

■ TECHNICAL DATA

The instruments with a transformer connection are supplied with a scale. This is because the scale must be chosen in accordance with the transformer.

MEASUREMENT RANGE	DIM. (WxHxD) mm	ORDER NO.
25 A	72x72x53	MGF17025
60 A	72x72x53	MGF17060
60mV, for shunt	72x72x53	MGF17000
Changeable scale, 60 A	72x72	MGS17060
Changeable scale, 100 A	72x72	MGS17100
Changeable scale, 200 A	72x72	MGS17200
Changeable scale, 300 A	72x72	MGS17300
Changeable scale, 400 A	72x72	MGS17400
Changeable scale, 500 A	72x72	MGS17500

■ VOLTMETER DC 72x72 mm



MG0B450F

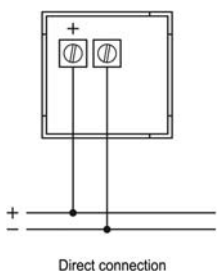

■ SCHRACK-INFO

- RC series
- 60 to 600 mV DC direct
- 1 to 600 mV DC direct
- Other measurement ranges upon request

MEASUREMENT RANGE	DIM. (WxHxD) mm	ORDER NO.
15 V	72x72x53	MGF27015
30 V	72x72x53	MGF27030
60 V	72x72x53	MGF27060
300 V	72x72x53	MGF27300

ANALOGUE MEASURING INSTRUMENTS FOR CP

MAXIMUM BI-METAL MOVING-IRON AMMETER DC, 96x96 mm

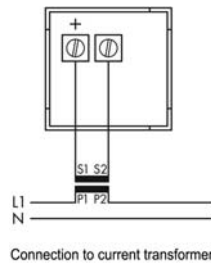

SCHRACK-INFO

- These instruments are made from a bi-metal measuring mechanism which shows the maximum current fixed by a red slave pointer, and a moving iron mechanism used to measure momentary current.
- Moving iron mechanism, overcurrent range $2x I_n$, max. intrinsic consumption 1,2 VA, class 1,5
- Bi-metal measuring mechanism, overcurrent range $1,2 I_n$, intrinsic consumption 2,5 VA, class 3
- RBC series, response time 15 min., current-transformer connection $..5A$, requires matching changeable scale
- Frequency 45-65 Hz
- Other changeable scales available upon request

MEASUREMENT RANGE	DIM. (WxHxD) mm	ORDER NO.
5 A, transformer connection, w/o scale	96x96x53	MGF49005
Changeable scale, 100-120-200/5 A	96x96	MG549100
Changeable scale, 200-240-400/5 A	96x96	MGF49200
Changeable scale, 600-720-1200/5 A	96x96	MGF49600
Changeable scale, 1000-1200-2000/5 A	96x96	MGF491K0
Changeable scale, 1500-1800-3000/5 A	96x96	MGF491K5

ACCESSORIES DC



MG900011/MG900015



MGZD0002

SCHRACK-INFO

- Terminal cover used to prevent accidental contact, fits all control panel devices

DESCRIPTION	DIM. (WxHxD) mm	ORDER NO.
MG		
Terminal cover 48C	48x48x10	MG900010
Terminal cover 72C	72x72x10	MG900011
Terminal cover 96C	96x96x10	MG900012
MOUNTING SET		
Additional mounting set (2 screws)		MGZ00001
Fast mounting set		MGZD0002
IP65 PROTECTION		
Front protection IP65 – 48C	48x48	MGZD4000
Front protection IP65 – 72C	72x72	MGZD7000
Front protection IP65 – 96C	96x96	MGZD9000

ELECTRONIC 1-PHASE/3-PHASE METERS

ELECTRONIC 1-PHASE METER



MGEI2125

SCHRACK-INFO

- 230V AC, 5 (25) A, 50 Hz with return stop
- Specification is equivalent EN 62052 / EN62053 CE
- Accuracy class 1
- Installation on DIN-Rail (DIN-EN 50022)
- 1 TE = 18 mm (DIN 43864)
- Regard of harmonic content up to 7kHz

TECHNICAL DATA

- S0-port: opto-electronic coupler (S0-DIN 43864)
- Rate of impulse: RA = 0,5 Wh/Imp.
- LED flash on, if power on the kWh-meter without load and is blink synchronic 0,5 Wh/Imp. = RL
- Display: 5 counts for kWh with 1 decimal place
- Input energy / friction loss: appr. 0,5W
- Rated voltage: 195V up to 253V
- Rated current: 0,025A up to 25A
- Inrush current at cos φ = 1 typical 22mA
- Temperature range: -20°C up to +50°C
- Air humidity max.: 75%, for a short time 95%

DESCRIPTION	ORDER NO.
Electronic 1-phase meter	MGEI2125

ELECTRONIC 3-PHASE METER



MGDIZ063

SCHRACK-INFO

- Frequency: 50Hz, 60Hz, 16²/₃ Hz
- Accuracy: active energy, class 1 or 2 according to IEC 62053-21
- Measuring types: active energy, 1 tarif register with non-reverse ratchet
- Data retention time: without voltage in the FLASH/EEPROM, at least 20 years
- Relative humidity: 90% at 40°C, non-condensing
- Operation mechanical button for operation of display

TECHNICAL DATA

		TRANSFORMER OPERATED METER 5111A	DIRECT CONNECTED METER 5(65)A
Voltage	4-wire	3x230/400V	3x230/400V
Starting current		2mA	20mA
Display	LC-Display digit size in the value range	8 digits, 3 with decimals digits	8 digits
Output (option)	number Opto-MOSFET		4 x 6 mm maximum 1 maximum 250 V AC/DC, 100 mA for impulse transmission (fulfils S0-specifications)
Energy supply	switched-mode power supply		3-phase from the measuring voltage
Power consumption per phase	voltage path current path		< 2.0 VA / < 1.0 W < 0.5 VA < 2.5 VA
EMC-characteristics	isolation resistance surge voltage		Isolation: 4 kV AC, 50 Hz, 1 min EMV: 4 kV, Impulse 1.2/50 μs, 2 Ω ISO: 6 kV, Impulse 1.2/50 μs, 500 Ω 10 V/m (under load)
Temperature range	resistance against HF-fields operation / limit and storage		-25°C...+55°C / -40°C...+70°C
Housing	dimensions class of protection degree of protection housing /terminal block housing material fire characteristics weight	6 pitch = 107.5 x 89.5 x 64.2 mm (B x H x D)	2 IP 20 polycarbonate flame-inhibiting (without halogen) approx. 400 g
Connection-cross section	current / neutral conductor voltage / auxiliary terminals	maximum 4 mm ² maximum 2.5 mm ²	maximum 16 mm ² maximum 2.5 mm ²
Further features		buffer battery for reading the display without power measuring of instantaneous values of power, voltage and current	

The meter can be connected to a 3- or 4-phase busbar with leftsided N connection.

DESCRIPTION	ORDER NO.
Electronic 3-phase meter	MGDIZ005
Electronic 3-phase meter	MGDIZ063

MODULAR LOW-CURRENT TRANSFORMERS

MODULAR, TCSM15 SERIES



MG900220

SCHRACK-INFO

- 2 MW housing with primary max. 15 mm
- Fastenings: DIN rail
- Class 3, 40 - 80 A
- Class 1, 100 -150 A
- Power outputs 2 / 3 / 5 VA
- Secondary current 1 A upon request
- 75 A model upon request

RANGE OF APPLICATION

- Fits all DIN-rail mounted devices such as RCCB switches etc., 45 mm slit
- Easy to thread through
- For crude display of measured value
- Space saving - only 2 MW wide

TIPS & TRICKS

Do not mix up direct of current (energy flow) when pushing through. The secondary load (e.g. 2 VA) must match the measuring device usage!

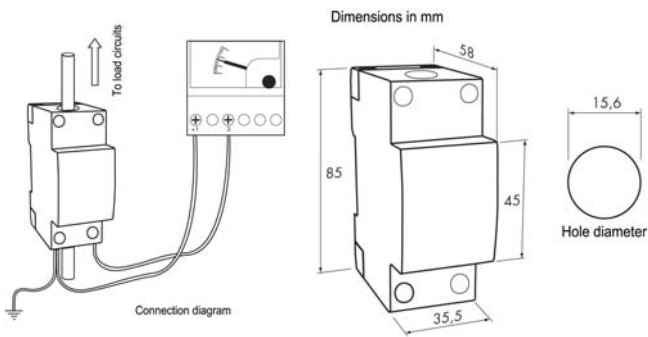

A	CLASS 1		CLASS 3	
	Secondary current 5A		Secondary current 5A	
	Type	VA	Type	VA
40			TCSM15 40 A	2
50			TCSM15 50 A	2
60			TCSM15 60A	3
80			TCSM15 80A	3
100	TCSM15 100A	3		
120	TCSM15 120A	5		
150	TCSM15 150A	5		

DESCRIPTION	DIM. (WxHxD) mm	ORDER NO.
Low-current transformer 40 A	35,5x58x85	MG900220
Low-current transformer 50 A	35,5x58x85	MG900221
Low-current transformer 60 A	35,5x58x85	MG900222
Low-current transformer 80 A	35,5x58x85	MG900224
Low-current transformer 100 A	35,5x58x85	MG900225
Low-current transformer 120 A	35,5x58x85	MG900226
Low-current transformer 150 A	35,5x58x85	MG900227

CURRENT TRANSFORMERS

CURRENT TRANSFORMER – TAR SERIES

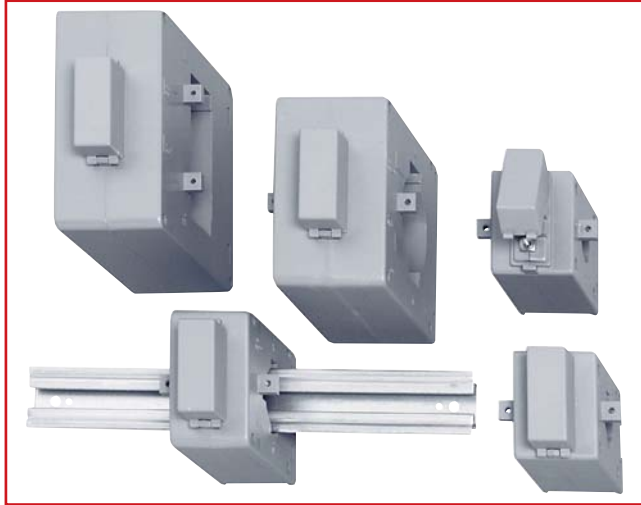

TAR

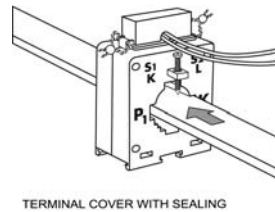
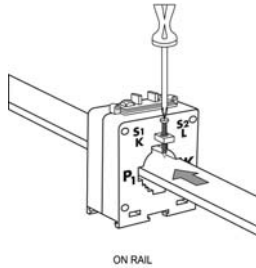
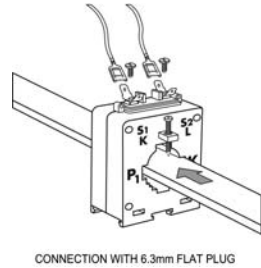
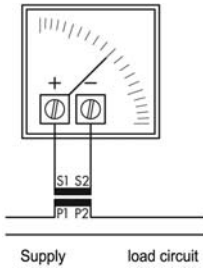

When winding the primary cable around the current transformer, you will obtain half of the primary current with each winding, while output and class remain unchanged.

EXAMPLE:

TAR 4D 200/5A WITH ONE CABLE ENTRANCE CONTAINS 100/5A WITH DOUBLE CABLE ENTRANCE CONTAINS 50/5A WITH 4 CABLE ENTRANCES

TECHNICAL DATA

- Observe current supply side P1/K, load side P2/L
- Before opening secondary circuit (e.g. to replace an instrument), firstly short-circuit secondary winding using jumpers S1/k and S2/l.
- Use class 0,5 for calibrated energy meters
Class 1 for display measuring devices and non-calibrated energy meters
Class 3 for relays and measuring devices w/o accuracy requirements (crude display)
- Observe load of measurement supply (e.g. 4m 1,5 mm² Cu conductors need 2,31 VA with 5A secondary current)

Current transformer							
Series	TAR PD2	TAR 1D	TAR 3D	TAR 4D	TAR 6	TAR 8	TAR 12
Design	Winding transformer	Snap-on transformer					
WINDING	horiz. Rail	25 x 3 (integrated)	30 x 10	40 x 10	64 x 20	80 x 30	125 x 50
	Cable	–	20	23	32	50	2 x 30 2 x 50
Primary current	Output (VA) Class 0,5	Output (VA) Class 0,5 1 3	Output (VA) Class 0,5 1 3	Output (VA) Class 0,5 1	Output (VA) Class 0,2 0,5 1	Output (VA) Class 0,5 1	Output (VA) Class 0,5 1
(A)							
40			3				
50	6		3				
60	6		3				
80	6		3				
100	6	3		3			
150		3		3			
200		3		4			
250		5		6		5 10	
300			5	6		5 10	5 10
400			5	10		5 6 12	6 12
500			6	10		5 6 12	10 20
600			6	10		5 10 20	10 20
800			6	10		5 10 20	10 20
1000				20		5 20 40	10 20
1200						20 40	15 30
1500						30 60	20 40
2000						30 60	20 40 30 60
2500						30 60	20 40 40 80
3000							20 40 40 80
4000							50 100

SCHRACK-INFO

- Enclosure in ABS plastic
- Secondary current: Standard 5 A (Other secondary currents upon request)
- Maximum operating voltage: 1.2 kV
- Test voltage: 6 kV at 50 Hz for 1 minute
- Thermic nominal short-time current (I_{th}): 40 I_{pN} /1 sec.
- Dynamic short-circuit current (I_{dyn}): 2,5 I_{th} /1 sec.
- Continuous overload: 1,2 I_{pN}
- Degree of protection IP30
- Rated frequency: 50/60 Hz
- Constructed in accordance with standards IEC 185, VDE 0414 and UN 21028
- Insulation class E (IEC 185)
- Tropic-proof, classes 0,2 upon request
- Safety/correction/overload current transformer upon request
- Including snap-on fastening onto foot of rail
- Other output-accuracy classes upon request

CURRENT TRANSFORMERS

FOR CABLE, 20 mm Ø TAR 1D SERIES

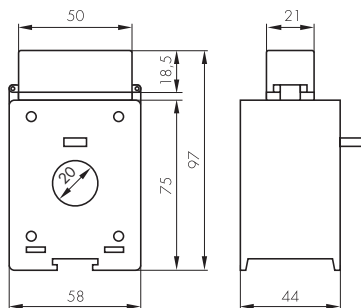

SCHRACK-INFO

- Also suitable for cable max. Ø 20 mm

TRANSFORMER	DIM. (WxHxD) mm	ORDER NO.
50/5 A	58x97x44	MG952005
60/5 A	58x97x44	MG952006
80/5 A	58x97x44	MG952008
100/5 A	58x97x44	MG952010
150/5 A	58x97x44	MG952015
200/5 A	58x97x44	MG952020
250/5 A	58x97x44	MG952025

FOR AGGREGATE RAIL 30x10 mm, TAR 3D SERIES

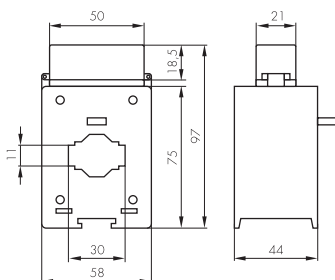

SCHRACK-INFO

- Also suitable for cable max. Ø 23 mm

TRANSFORMER	DIM. (WxHxD) mm	ORDER NO.
50/5 A	58x97x44	MG954005
60/5 A	58x97x44	MG954006
100/5 A	58x97x44	MG954010
150/5 A	58x97x44	MG954015
200/5 A	58x97x44	MG954020
250/5 A	58x97x44	MG954025
300/5 A	58x97x44	MG954030
400/5 A	58x97x44	MG954040
500/5 A	58x97x44	MG954050
600/5 A	58x97x44	MG954060

CURRENT TRANSFORMERS

FOR AGGREGATE RAIL 40x10 mm, TAR 4D SERIES

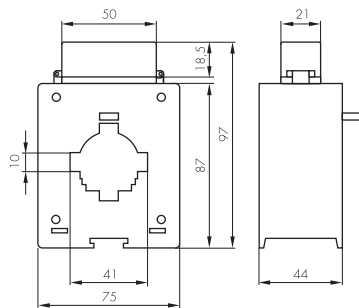

SCHRACK-INFO

- Also suitable for cable max. \varnothing 32 mm

TRANSFORMER	DIM. (WxHxD) mm	ORDER NO.
400/5 A	75x97x44	MG955040
500/5 A	75x97x44	MG955050
600/5 A	75x97x44	MG955060
800/5 A	75x97x44	MG955080

FOR AGGREGATE RAIL 60x20 mm, TAR 6 SERIES

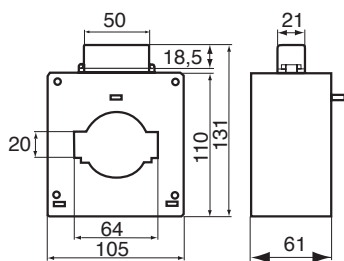

SCHRACK-INFO

- Also suitable for cable max. \varnothing 50 mm

TRANSFORMER	DIM. (WxHxD) mm	ORDER NO.
800/5 A	105x131x61	MG957080
1000/5 A	105x131x61	MG957100
1500/5 A	105x131x61	MG957150
2000/5 A	105x131x61	MG957200

FOR AGGREGATE RAIL 80x30 mm, TAR 8 SERIES

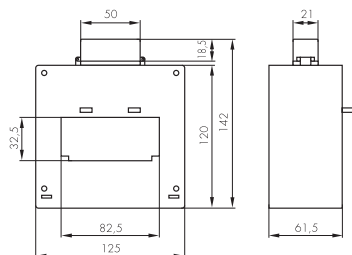

SCHRACK-INFO

- Also suitable for cable max. \varnothing 30 mm

TRANSFORMER	DIM. (WxHxD) mm	ORDER NO.
1000/5 A	125x142x61,5	MG958100
1500/5 A	125x142x61,5	MG958150
2000/5 A	125x142x61,5	MG958200
2500/5 A	125x142x61,5	MG958250

CURRENT TRANSFORMERS

FOR AGGREGATE RAIL 125X50 mm, TAR 12 SERIES

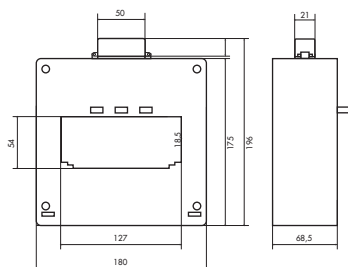

TRANSFORMER	DIM. (WxHxD) mm	ORDER NO.
2000/5 A	180x196x68,5	MG959200
2500/5 A	180x196x68,5	MG959250
3000/5 A	180x196x68,5	MG959300

HOUR METER

■ HOUR METER FOR CONTROL PANEL INSERT



BZ326413



BZ326415

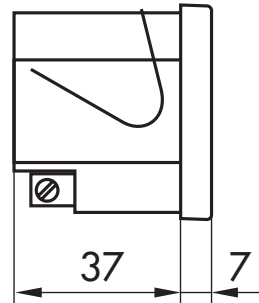
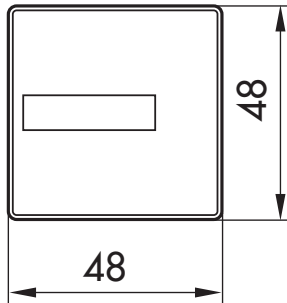

■ SCHRACK-INFO

- Ambient temperature -20° C to +50° C
- Accuracy: Mains synchronous
- Degree of protection IP 20 or IP 54
- Protection class II
- 48 x 48 front plate with latch fastener
- Universal connection
- Power consumption 1A
- 10-50 V DC: round design
- Front panel cut-out 45 x 45 mm

■ RANGE OF APPLICATION

Used to measure operating time, down time, warranty time, switch time, working time, maintenance intervals, service life, etc.

RATED VOLTAGE	DIM. (WxHxD) mm	ORDER NO.
240 V AC IP 20	48x48x44	BZ326413
230 V AC IP 54	48x48x44	BZ326414
Shield	55x55	BZ326416

■ AS MODULAR INSERT/ WALL-MOUNTING



BZ326418



BZ3264DF

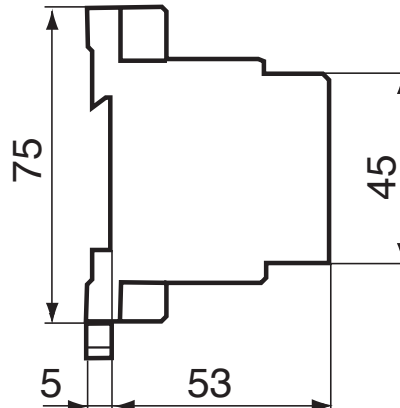
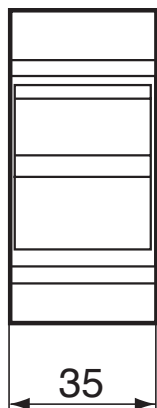

■ SCHRACK-INFO

- Universal connection
- Ambient temperature -20° C to +50° C
- Accuracy: Mains synchronous
- Degree of protection IP 20
- Protection class II
- Power consumption 1A

■ RANGE OF APPLICATION

Used to measure operating time, down time, warranty time, switch time, working time, maintenance intervals, service life, etc.

RATED VOLTAGE	DIM. (WxHxD) mm	ORDER NO.
For 230 V AC	35x75x58	BZ326418

TRANSFORMERS, INDUCTORS, POWER SUPPLY UNITS

TOP-TECHNIC



TRANSFORMERS

TOP-TECHNIC



POWER SUPPLY UNITS